

Innovative and tailor-made solutions for drilling and rock excavation in underground mining

By Jerzy Nadolny
CEO of Mine Master Ltd.

Basic information about Mine Master

Location: Wilków / Złotoryja / Poland

Employees: Total 250 people including 70 University graduates with Master's Degree, 45 of which are Engineers

Workshop Area: 8 000m²

Service Division: Service Office located in Polkowice

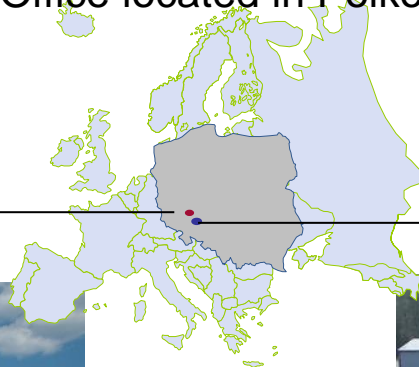

Polkowice - Service

Wilków - Factory



MOVIE

Key facts

To date MINE MASTER has supplied over **1400** machines to the global market.
213 MINE MASTER rigs are currently in operation at KGHM Polish Copper mines.

Mine Master is a supplier of:

- 🏠 64% drill rigs for KGHM
- 🏠 90% roof bolters for KGHM



Main markets

- | | |
|------------|--------------|
| 🏠 Poland | 🏠 Russia |
| 🏠 Turkey | 🏠 Estonia |
| 🏠 RSA | 🏠 Australia |
| 🏠 Zimbabwe | 🏠 Chile |
| 🏠 Botswana | 🏠 Pakistan |
| 🏠 Iran | 🏠 India |
| 🏠 Nepal | 🏠 Kazakhstan |



Applications

Hard Rock Mining

Methods:

- Room and Pillar, Cut and Fill, Block Caving, Sub Level Stopping
- Production and Development

Materials:

- Silver, Gold, Iron, Zinc, Lead, Platinum, Chrome, Nickel, Magnesite, Diamonds
- Compressive strength of rocks: up to 400 MPa



Soft Rock Mining

Methods:

- Room and Pillar, in combination with Mechanical Cutting
- Production and Development

Materials:

- Rock Salt, Potash, Limestone, Marble, Clay Shale, Oil schist etc.
- Compressive strength of rocks: up to 120MPa



Product range – Low profile



Drill rigs		Roof bolters		Special vehicles
Hard rock	Soft rock	Hard rock	Soft rock	
Face Master 1.4	Face Master 1.4R	Roof Master 1.4	Roof Master 1.4	SWOI 1.4
Face Master 1.7	Face Master 1.7R	RLP1400-1B	Roof Master 1.4Automatic	SWOI 1.7
Face Master 1.7L	Face Master 1.7LR	Roof Master 1.7	Roof Master 1.7	
Face Master 1.7D	Face Master 1.7DR	RLP1700-1B	Roof Master 1.7D	
		Roof Master 1.7D	Roof Master 1.7Automatic	
		Roof Master 1.8AWK		

Product range – Narrow vein

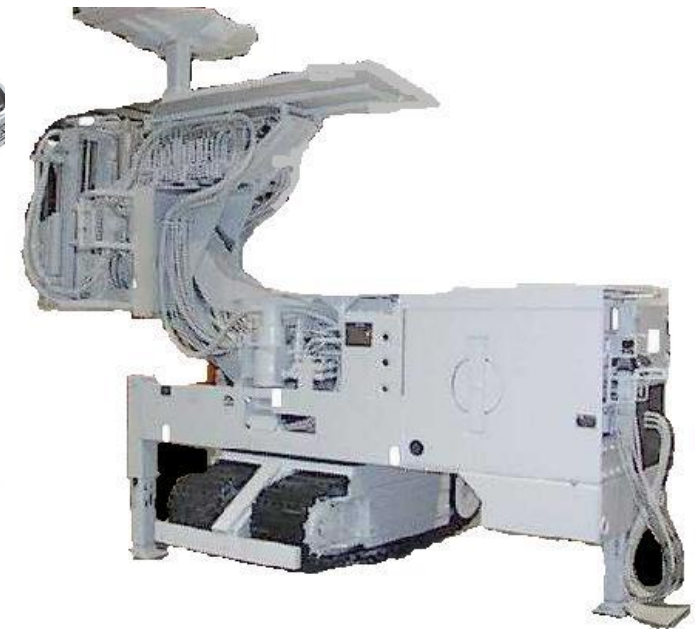

Drill rigs		Roof bolters
Hard rock	Soft rock	Soft rock
Face Master 2.5NVDR	Face Master 2.5R	Roof Master 2.0 SWKB

Product range – Tunneling

Face Master 1.7

Face Master 2.3-1B

Face Master 2.3

Face Master 3.0 Mk3



Product range – long hole drilling



Production Master 2.1
Narrow vein application

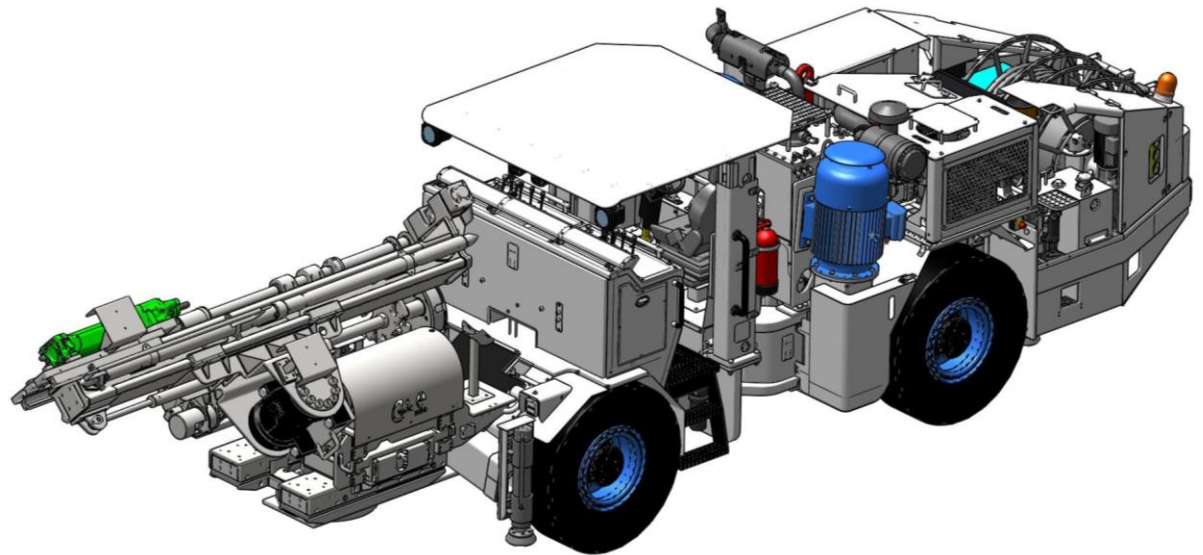

Production Master 2.3
System with rod magazine

New developments

The tight space gives a lots of challenges to the equipment suppliers, especially to provide very good reliability, safety and productivity in limited area. Mine Master took this challenge and for its clients in Australia, Russia nad Turkey designed a new concept of a narrow vein drilling rig, which offers much bigger variety of utilization of the equipment.



Individual approach- Germany

For GSES salt mine Mine Master designed a machine with rotary drilling system and air- mist flushing system. Due to methane hazards the working unit and electric system is ATEX certified.



- ↑ Face Master 1.8RS in GSES, Germany
- ← Roof Master 2.3 AWK in GSES, Germany

Individual approach – Chukotka

To design a drilling machine which would work in the permafrost was a big challenge.

In the average temperature from -15°C to -10°C the drilling process is conducted without water flushing and debris is removed by using air flushing system. Besides the reduction of labor costs the client also benefit from savings on material costs of diesel and energy.



Mine Master delivered 6 units of Face Master 1.7D. to Arteli Starateley Schachter Mine in Chukotka

Individual approach – Russia

In a mine in Russia, a world's largest producer of nitrogen-based fertilizers and organic synthesis products the orebody contains pockets of methane therefore a completely explosion-proof machine was needed. Mine Master was the only European OEM producer who took the challenge to design the machine and to go through a very strict ATEX certification.



Mine Master delivered 3 units of
Roof Master 1.8 AWK
to EuroChem in Russia

Individual approach – KGHM

KGHM O/ZG Rudna mine has been testing the bolter Roof Master 1.7A with automatic mast developed in co-operation with J.H. Fletcher (US). With this rig the operator can install 8 bolts without replacing a roof bit (average number of bolts per 1 bit – 9.2 bolts). Thanks to the compressed air cleaning system for clogged drill rod it is possible to drill in laminated roof. The big advantage is the automatic resin inserting system, which allows to refer a resin inserter in free coordinates and thus facilitates the job of the operator.



Roof Master 1.7A bolting rig



Individual approach – KGHM

A chance in improving the work effectiveness is seen in automation and monitoring of production process. The computer aided drilling results in obtaining a better geometry of excavations, improving the quantity of mined material with a reduction of explosives needed and supportive works. For KGHM Mine Master equipped Face Master 1.7L with FGS monitoring system.

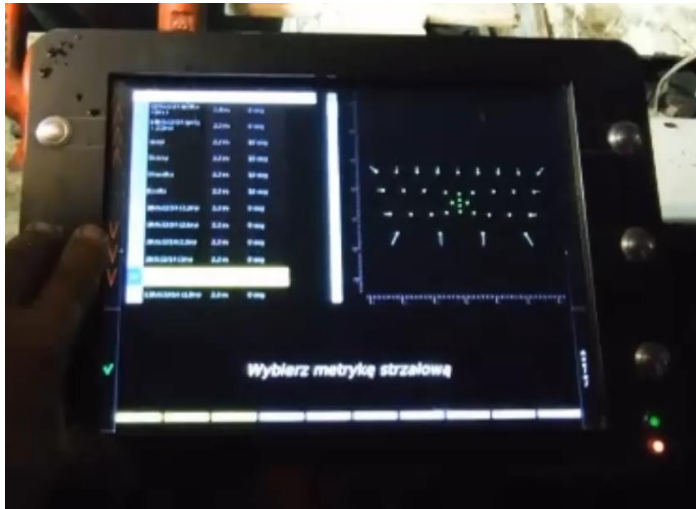

Development focus - „Intelligent mining”

High speed connection systems give an opportunity to make mining work safer, more cost effective and monitored from the surface.

Future of underground drilling lies in:

➤ Monitorig of bolting and drilling parameters

➤ Drilling according to the designed drilling pattern

➤ Automatic bolting

➤ Transmission of data by means of main power cable and fiber

➤ Remote controlled drilling/bolting

Number of installed bolts, tightening of torque, parameters of hydraulic system.

BCS (*Bolt Counting System*)

FGS (*Feeder Guiding System*)
Feeder Guided Position in accordance with drilling pattern,

Control of: hole depth, quantity of drilled holes and drifter parameters.

LEVEL 3

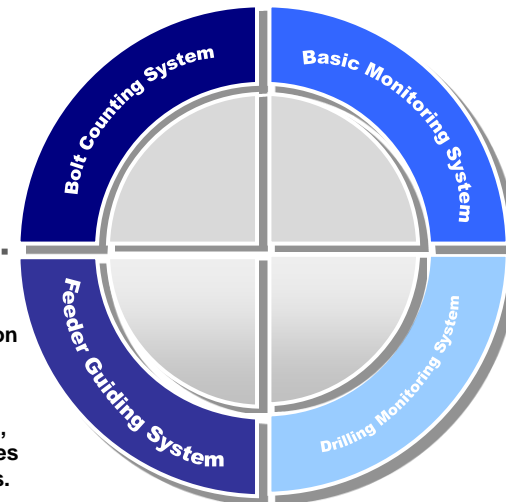

Tramming and hydraulic systems parameters.

LEVEL 1

BMS (*Basic Monitoring System*)

DMS (*Drilling Monitoring System*)

Control of: hole depth, quantity of drilled holes and drifter parameters.

LEVEL 2

Development focus

Battery driven drilling rigs and bolters for underground operations

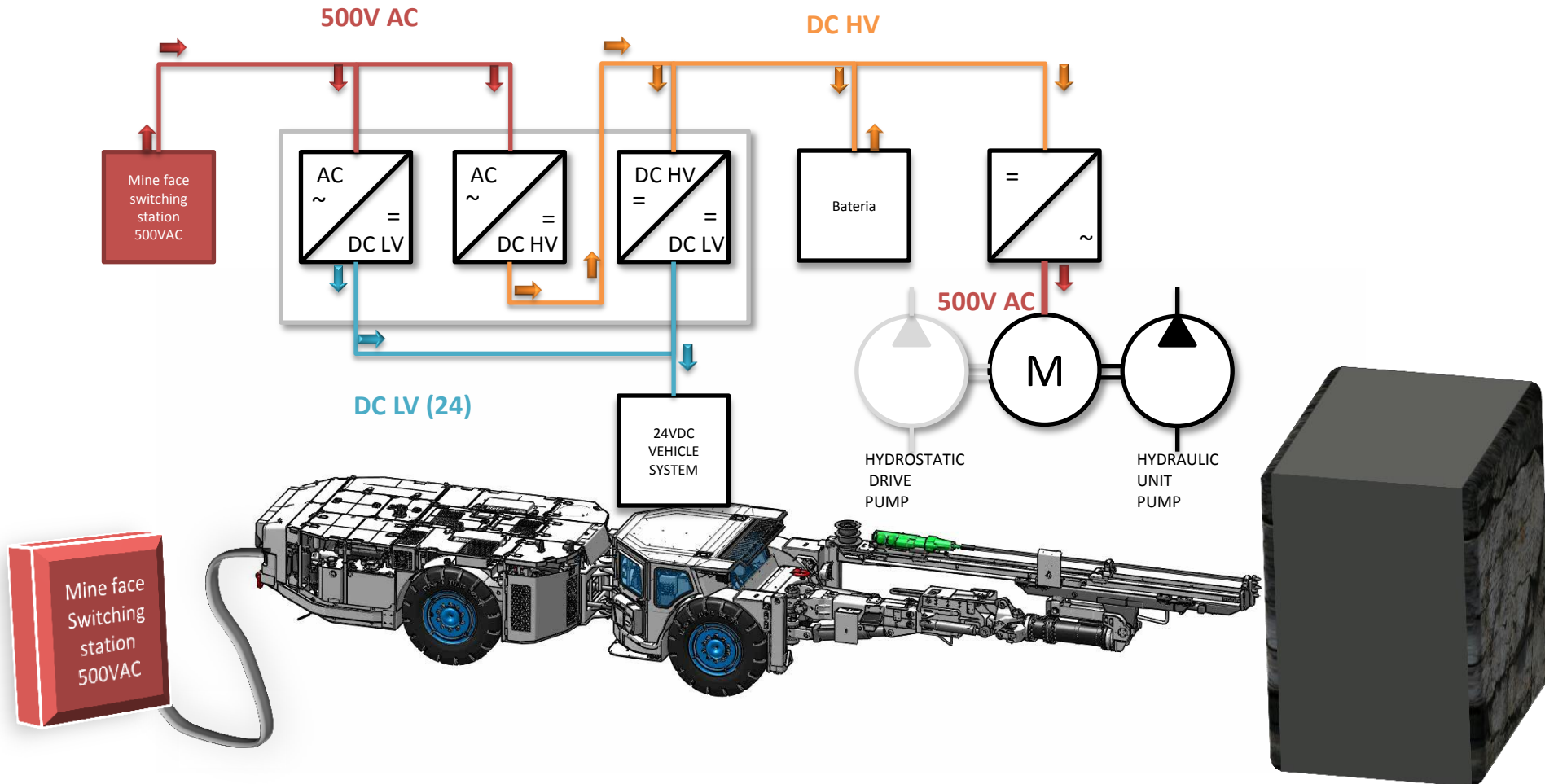



Thank you for your attention

tel: +48 76 87 83 511

fax: +48 76 8784101

Email: info@minemaster.eu

<http://www.minemaster.eu>